

T H E

AMERICAN JOURNAL OF SCIENCE.

[T H I R D S E R I E S .]

ART. XXII. — *On the New Action of Magnetism on a Permanent Electric Current*; * by E. H. HALL, Assistant in Physics at the Johns Hopkins University.

IN the early part of last winter there was published in the *American Journal of Mathematics*† an account of some experiments which prove that an electric current, as distinguished from the conductor bearing the current, is acted upon by magnetic force in a manner altogether different from that in which ordinary induction is known to take place. The new phenomenon was in short the action of a permanent magnetic force on a permanent electric current. Up to the time when the above-mentioned article was written this new action had been observed in only one conducting material, gold. In the present article will be given the results of observations with several other conductors; but first it seems worth while to give some account of various closely related experiments which, though resulting negatively, are not entirely devoid of interest.

In the previous article the fact was mentioned that a form of apparatus had been devised which, it was thought, might reveal the new action in the shape of an increase of resistance in the conductor. The plan, as modified in accordance with a suggestion of Professor Rowland, was to employ as the conductor to be experimented upon a circular disk of gold leaf, in which the current entering at the center would radiate to a thick ring at the edge and so pass off by a wire attached to the ring. In such an apparatus under ordinary conditions the electromotive force, and so the flow of electricity, would be

* In its original form this article was a thesis for the degree of Doctor of Philosophy. Some alterations have been made in preparing it for publication.

† Vol. II. page 287, 1879; republished in this Journal, March, 1880.

AM. JOUR. SCI.—THIRD SERIES, VOL. XX, No. 117.—SEPT., 1880.

along the radii of the disk, but if a strong magnetic force were made to act perpendicularly to the face of the disk a new electromotive force would be set up, which would be always perpendicular to the direction of the magnetic force and to the actual direction of flow of the electricity at any instant in every part of the disk. The actual electromotive force therefore, under which the electricity would flow, would be compounded of two, one of which would in general have the direction of the radii of the disk, while the other would be nearly at right angles to this, though changing its direction constantly as the flow of electricity continually veered from its normal course under the resultant action of the two electromotive forces. The resulting path of the electricity from the center to the circumference of the disk would be, not a straight line as under normal conditions, but a spiral. This path being longer than the straight line, we should expect an increase of electrical resistance in the disk of gold leaf. Before any very extended experiments had been made with this apparatus, however, it was pointed out by Professor Rowland that the increase of resistance which might be looked for in this case would be exceedingly small, too small probably to be detected. This experiment was therefore abandoned for the time at least.

The next experiment to be described was a very simple variation upon the main one, and before going farther it may be well to give a drawing of such a plate as has been used in making most of the observations to be hereafter recorded.

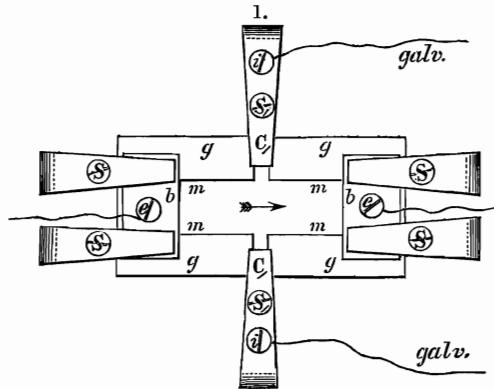

In fig. 1, which is about one-half the actual size of an ordinary plate, *g g g g* represents the plate of glass upon which the metal strip *m m m m* is mounted. Contact with this strip is made at the ends by the two thick blocks of brass *b, b*, which are held firmly in place by the four brass clamps worked by means of the screws *S, S, S, S*. The main current of electricity

enters and leaves the metal strip by means of the binding screws e, e . Running out from the middle of this strip are two projections which make contact with the clamps C, C' , worked by the screws S, S' . From the screws i, i' wires lead to the Thomson galvanometer. The projections from the metal strip just alluded to make the apparatus very easy to adjust, for by scraping off little particles from the proper part of the projections, while the current is allowed to run through the metal strip, the current through the Thomson galvanometer may be reduced to the extent desired.

In ordinary experiments such a plate as that just described is placed between the poles of the magnet in such a position that the direction of magnetic force would be represented by a perpendicular to the plane of the paper in the above drawing.

2.

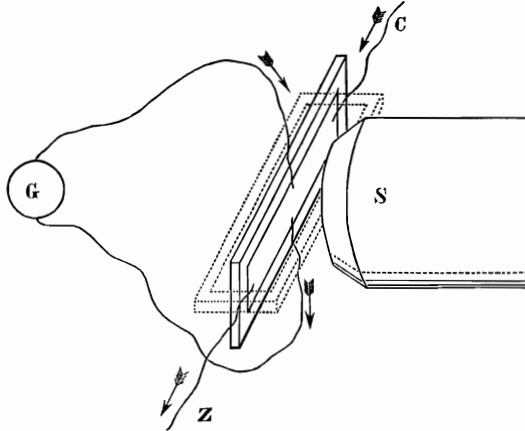

In the variation upon the main experiment a plate was employed similar to the above, but narrower and with very short side clamps. This plate was first placed between the poles of the magnet in the usual position as shown by the heavy lines in fig. 2.

With this arrangement a permanent deflection of about 30 cm. on the scale before the Thomson galvanometer could be obtained by reversal of the magnet current. Leaving now the distance between the poles very nearly the same as before and using, both in the magnet and the gold strip, as nearly as possible the same strength of current which had just been employed in the previous trial, the plate was turned into the position indicated by the dotted lines in fig. 2. With this second arrangement no action of the kind previously seen was detected, or at least none that could with certainty be distinguished from the direct action of the magnet on the Thomson

galvanometer. This latter effect produced a deflection of only a few mm. and could not have masked any considerable action of the kind looked for.

The first part of this experiment then shows our main fact, viz: that in a conductor subjected to the given conditions a permanent electromotive force is at once established which has a direction perpendicular to the direction of magnetic force and perpendicular to the direction of the primary current in the conductor. The second part of the experiment shows that under similar conditions no electromotive force is set up in the direction of the magnetic force, or at least none of the same order of magnitude as that described above.

The third experiment to be described was made at the suggestion and desire of Professor Rowland. It was to test for an action of the magnet on the lines of static induction in glass. A thick piece of plate glass about four cm. square was taken and a hole about four mm. in diameter was drilled through each of the four lateral faces. These four holes were all directed toward the center of the glass and each extended to within about seven mm. of this point. If the holes had met they would have formed two cylindrical channels at right angles to each other and extending straight through the glass from lateral face to lateral face. In each hole a loosely fitting plug of brass several mm. long was placed and securely fastened with a cement of insulating material. Leading out from each plug was a wire which was insulated for some cm. by being surrounded with a glass tube. The piece of plate glass thus prepared was placed between the poles of the magnet, precisely as a plate bearing a strip of gold would be. One of the brass plugs was placed in connection with the inner coating of a battery of Leyden jars charged by means of a Holtz machine, the opposite plug being in connection with the outer coating of the jars and with the earth. The other two plugs were placed in connection with separate quadrants of a Thomson electrometer. The quadrants were both insulated from the earth. The electrometer was sufficiently sensitive to deflect the spot of light about 170 mm. for the electromotive force of a Bunsen cell, or 340 mm. on reversing the connections with such a cell. The battery of Leyden jars was charged to a potential sufficient to give a spark of two or three mm. The connections being thus made, the position of the spot of light was observed and the magnet then operated with the purpose of discovering, if possible, any consequent change of position of the spot of light which would indicate an action of the magnet on the lines of static induction in the glass. The observation failed to establish the existence of any such action. The electrometer being in a very sensitive condition the spot of light was rather unsteady, so that any

very slight effect of the kind looked for would not have been detected, though it is probable that if a reversal of the magnet had caused a change of four mm. in the position of the spot of light, this effect would have been apparent.

We may therefore conclude that any change of relative potential on the quadrants of the electrometer caused by reversal of the magnet was probably less than $\frac{1}{80}$ of that caused by reversing the connections of the electrometer with a Bunsen cell, as mentioned above. If now we estimate the difference of potential between the plugs A and B, connected with the Leyden jars, to have been, as indicated by the length of the spark, equal to that which would be produced by 10,000 Bunsen cells in series, we may conclude that any difference of potential between the other plugs C and D which was caused by the action of the magnet, must have been less than $\frac{1}{80000}$ of the difference of potential between A and B. We must remember, however, that any change of potential on C and D had to be extended as well over the comparatively large area of the electrometer quadrants. Professor Rowland has roughly estimated the capacity of the quadrants as twenty times that of the plugs C and D. If, therefore, these plugs had not been attached to the electrometer, any difference of potential between them due to the action of the magnet would have been twenty times as great as in the actual case, so that instead of $\frac{1}{80000}$ we have $\frac{1}{40000}$ of the difference of potential of A and B as the superior limit of the difference of potential of C and D which the magnet might possibly have produced, if C and D had not been connected with the electrometer. Representing the former difference of potential by E, the latter by E', and the strength of the magnetic field, about 4000 (cm.-grm.-sec.), by M, we have for this case of static induction in glass $\frac{E'}{E \times M}$, if not zero, is less than $\frac{1}{100000000}$.

Turning to the analogous case of current electricity in the various metals and representing now by E the difference of potential of two points a centimeter apart in the direction of the current, and by E' the difference of potential of two points a centimeter apart in a direction at right angles to that of the current, while M has the same signification as before, we may write, as a very rough estimate for the case of iron, $\frac{E'}{E \times M} = \frac{1}{10000000}$, while for tin the value of this ratio may be as small as $\frac{1}{8000000000}$. We may therefore conclude that the equipotential lines in the case of static induction in glass, if affected at all by the magnet, are affected much less than the equipotential lines in the case of a current in iron, but we can not say that any such possible action in glass has been shown

to be smaller than the analogous action in the case of a current in tin.

I now go on with an account of further investigation of the phenomenon actually discovered and already in some measure described in my previous article. When writing that article it seemed to me instructive to deduce the ratio, $\frac{E}{E'}$, of the difference of potential per cm. on the longitudinal axis of the gold leaf strip to that per cm. on the transverse axis. There were thus obtained for the experiments made values of $\frac{E}{E'}$, ranging from 3,000 to 6,500 according to the strength of the magnetic field.*

At that time I supposed that the ratio $\frac{E \times M}{E'}$ would prove to be a constant, not only for different strips of one metal, but for all conductors. Subsequent experiments showed that this was not the case, and in this article the results obtained will be expressed by the ratio $\frac{M \times V}{E'}$, where E' has the same signification as before, while M now expresses the strength of the magnetic field in cm.-grm.-sec. units and $V = \frac{C}{S}$ †, the strength of the primary current divided by the area of section of the conductor. This ratio does not prove to be the same constant for different metals but for any particular metal it seems much more nearly a constant than the ratio $\frac{E \times M}{E'}$ given above would be.

It may seem to those who read the following pages that an unnecessary amount of study has been devoted to gold. It must be remembered, however, that many readers of my previous article were not fully convinced by the evidence there adduced that any really new principle had been discovered, thinking that the explanation of the phenomenon described was possibly to be found in some such fact as the state of mechanical strain, into which the strip of gold leaf would be thrown in its endeavor to move across the lines of magnetic force in obedience to the perfectly well known laws of the

* In obtaining this latter quantity, which was called M , a serious error was made and the value given was probably not much more than half what it should have been. This fact was mentioned in a note when the article in question was republished in this Journal, Mar., 1880, p. 200, and p. 235.

† This quantity V may be said to bear an intimate relation to the absolute velocity of the electricity, for if we were to take as the unit velocity of electricity that of a unit current flowing through a conductor of unit cross-section, the velocity in any particular case would be a quantity $\frac{C}{S}$.

action of magnets on conductors bearing currents. This being the case, it seemed desirable to make experiments with several strips of the same metal and determine whether the ratio $\frac{M \times V}{E}$ would prove to be a constant for all. The dimensions of many of the strips used, of whatever metal, are given below, and in order that the conditions to which they were variously subjected may be more fully understood, there will be given in many cases the strength of the magnetic field in absolute units and the strength of the primary current through the strip, the latter being expressed in terms of the constant, k , of the tangent galvanometer used to measure it. This constant there has been no occasion to determine exactly, but it is about .07.

It will probably be readily admitted that the results obtained cannot be accounted for without admitting substantially all that was really claimed in the previous article. Even if no such quantitative investigation had been made, however, there would still be one fact inexplicable on the theory of an accidental cause for the phenomenon under consideration. The arrows in fig. 2 show the direction of the transverse current relatively to the direct current in gold, the magnet pole, S, being a south pole, i. e., the pole attracting the north pointing end of a needle. This relation between the directions of the two currents and the magnetic force is the same in all of the four gold plates which have been examined in this particular. The same uniformity is observed in the four silver plates, and the three iron plates, which have been tested in the same way. With the two plates of tin which have been examined there has been a trifle of uncertainty upon this point, as the effect in this metal is at best very small, but this uncertainty is hardly sufficient to cast doubt upon the correctness of the rule that, so far as observation has gone, the relative direction of the transverse current is always the same for any particular metal. This uniformity in so many cases could hardly be accidental.

This matter of direction is evidently one of fundamental importance. The direction was found to be the same for silver as for gold, these being the two metals first examined. Professor Rowland, however, predicted that the direction would be reversed in iron and experiment verified the prediction. Prof. Rowland's comments upon the significance of this discovery are already before the public*. It is a seemingly awkward fact that in nickel, next to iron and cobalt the most strongly magnetic substance, the direction of the transverse current is the same as in gold. This fact will be discussed further on. The conductors which have, up to this date, been subjected to ex-

* Am. Journ. Math., vol. ii, p. 355.

periment are gold, silver, iron, tin, nickel and platinum. The direction is the same in all except iron.

The extreme irregularity in the results obtained in the early part of this course of experiments was due to various causes, only one of which is worth mentioning here. This source of error was the shape of the magnet poles, which, being intended for the study of the magnetic rotation of polarized light, were perforated axially by a hole several mm. in diameter. With these poles the magnetic force was found to vary many per cent in different parts of the field. These poles were subsequently replaced by solid ones, and a sufficiently uniform field was thus secured. It will, however, be noticed that even after this change the results obtained on the same day and with the same plate often vary by several per cent. Probably quite a part of this irregularity was due to the faulty manner in which the tangent galvanometer, which measured the strength of the primary current through the strip, was introduced. This source of error can probably be avoided in future measurements. Again it is to be remembered that the strength of the transverse current was determined by a delicate Thomson galvanometer, an instrument far more sensitive than accurate. In using comparatively thick strips of metal there is especial liability to error from this source, as a low resistance galvanometer must then be employed, which may easily change in sensitiveness several per cent within an hour.

Much of the disagreement to be observed in the results obtained with different plates of the same metal, is no doubt to be explained by the difficulty of determining with anything like accuracy the thickness of the various strips employed. I have tried to determine approximately the thickness of the thinnest films used by measuring the electrical resistance, but this method, as will be seen, is exceedingly faulty. The thicker strips have been weighed before being placed on the glass, but even this method fails to determine the effective thickness accurately. Even if the specific gravity were the same for all the strips, and it probably is not, the value thus obtained for the thickness would give only the average thickness, and this is by no means the effective thickness. It will be remembered that the connections leading to the Thomson galvanometer are placed opposite to each other with the width of the metal strip between them. The effective thickness is the average thickness along the line joining these two side connections. Gold foil is obtained in sheets ten or twelve cm. square. It will be seen further on, that in one case two strips cut from similar positions in the same sheet differed in average thickness about seven per cent. This being the case it seemed quite possible that the effective thickness of any strip, as defined above, may

differ many per cent from the mean thickness indicated by the weight.

All these sources of error being considered, the discrepancies which will be observed in the results to be given, will not be surprising.

A single complete series of observations consisted of the following parts:

1st. A determination of the extent to which the indicator of the Thomson galvanometer was affected by the direct influence of the magnet and the magnetizing current.—All that it was necessary to ascertain in this case was the change in position of the galvanometer indicator caused by reversing the current through the magnet. This usually amounted to one or two mm. and subsequent readings of the Thomson galvanometer were, when it was necessary, corrected accordingly.

2nd. A determination of the strength of the magnetic field.—This was done by withdrawing suddenly from the field a small coil consisting of a few turns of wire and observing the effect of this action on a delicate galvanometer placed in circuit with the coil.* The galvanometer was used with a mirror and scale and the readings actually obtained were reduced by the formula

$$\sin \frac{\Phi}{2} = \frac{n}{4r} \left(1 - \frac{11}{2} \left(\frac{n}{4r} \right)^2 \right)$$

where n is the actual reading and r the distance from the mirror to the scale. The constant of the galvanometer not being known, its sensitiveness, that is the significance of its readings in absolute measure, was determined whenever the strength of the magnetic field was to be found. This was effected by means of an earth inductor placed in circuit with the galvanometer and the test coil used with the magnet. The determination of the strength of the magnetic field therefore involves two series of observations, one with the earth inductor and one with the test coil.

3d. A determination of the sensitiveness of the Thomson galvanometer.—This was done by sending through it a current of known strength obtained by shunting the current from a Bunsen cell, the main current being measured with a tangent galvanometer.

4th. The main experiment.—The primary current through the metal strip measured with the tangent galvanometer just spoken of, and the effect of reversing the magnet observed on the scale of the Thomson galvanometer.

5th. Another determination of the sensitiveness of the Thomson galvanometer.—Method as described above.

* Rowland. "On a Magnetic Proof Plane," this Journal, vol. x, p. 14, 1875.

6th. Another series of observations with the test coil.

7th. Another series of observations with the earth inductor.

8th. Another determination of the direct action of the magnet on the Thomson galvanometer.

If, as was usually the case, several series were to be made with the same plate in one day, for the purpose of using primary currents of various strengths, the sensitiveness of the Thomson galvanometer was tested before each main series of observations and after the last.

The mean of two values found for the sensitiveness of the Thomson galvanometer was of course taken to be the sensitiveness during the series of observations intervening. It was not found necessary to determine the strength of the magnetic field more than twice during a half day's observations.

In working up these observations the following formula applies:

$$\frac{M \times V}{E'} = \frac{7460 H \frac{\sin \frac{\Phi}{2}}{\sin \frac{\Phi'}{2}} \frac{k \tan \alpha}{wt}}{\frac{dk \tan \Theta pr}{d'w}}$$

M , V , and E' have been already defined.

7460 = twice the integral area of the earth inductor divided by the integral area of the test coil. Twice the simple ratio of these two areas is taken, for the reason that the earth inductor coils are turned through 180° when used.

H = horizontal intensity of earth's magnetism at position of earth inductor.

$\sin \frac{\Phi}{2}$ = a quantity relating to effect on the galvanometer used with test coil, produced by withdrawing the latter from the magnetic field.

$\sin \frac{\Phi'}{2}$ = a similar quantity relating to the galvanometer and the earth inductor.

k = constant of tangent galvanometer.

α = reading of tangent galvanometer when measuring primary current through the metal strip.

w = effective width of metal strip.

t = effective thickness of metal strip.

d = difference in readings on the Thomson galvanometer scale caused by reversing magnet in the main experiment.

d' = difference in readings on same scale caused by reversing current in determining sensitiveness of the Thomson galvanometer.

Θ = reading of tangent galvanometer when measuring current used to determine sensitiveness of Thomson galvanometer.

p = proportion of above current which passes through the Thomson galvanometer.

r = total resistance of circuit containing Thomson galvanometer during main experiment.

The above formula reduces to the form

$$\frac{M \times V}{E'} = \frac{7460 \sin \frac{\Phi}{2} \tan \alpha d' H}{t d p r \tan \Theta \sin \frac{\Phi'}{2}}$$

It will be seen that k and w have disappeared. The elimination of w is a very important fact as this would be an exceedingly difficult quantity to determine with accuracy. As the case stands, it is not at all important to preserve the form of the metal strip after its thickness has been determined. This makes the adjustments of the side connections (see fig. 1), leading to the Thomson galvanometer, a matter of considerable ease.

The following pages give some details of the study of the various metals examined.

GOLD.

The experiments which furnished the results already published, were made with gold leaf so thin as to be transparent. In order to reduce those results to the form since adopted, it would be necessary to know the thickness of the gold strip. This thickness might be determined roughly, if we knew the the specific resistance of the material and the actual resistance of the strip, which is now destroyed. The latter value is known approximately, and, by assuming the specific resistance to have been that of pure gold, we might arrive at a value of the ratio $\frac{M \times V}{E'}$. This value, however, would be very much larger than that obtained when thicker strips of metal are used, and facts to be hereafter mentioned make it appear quite probable that the thickness of the strip, as above arrived at, is several times smaller than the true thickness.*

Without attempting therefore any accurate determination of the constant of this first strip (A), I pass on to

Gold Leaf, Plate (B).

This plate also is of very thin metal, and in general I shall use the term gold *leaf*, when speaking of the metal in this shape, and use the term gold *foil* to denote the strips of considerable thickness.

* See also Albert v. Ettingshausen, "Bestimmung der Absoluten Geschwindigkeit." etc. Sitzungsberichte Akad. Wien, vol. lxxxi. p. 446, 1880. He found the value of the thickness indicated by the weight in similar cases, to be from four to ten times as great as that indicated by the resistance.

This second plate of gold leaf was not constructed until after several thick plates had been tried and found to give very different results from those obtained with the first thin plate in the manner described above. Thinking that some experimental error in the first measurements might account for the discrepancy, and the first plate being destroyed, I constructed the second one. In making observations with this plate I first used the high resistance Thomson galvanometer, whereas the low resistance instrument had been used with the thick plates. Thinking that I might in changing instruments have fallen into some error, I afterward made another series of observations with the same plate, but using the low resistance galvanometer. The results were, the thickness here also being estimated as above described,

March 18, with high resist. galv.,	$\frac{M \times V}{E'}$	=	622×10^{10}
“ “ “ “ “		=	$637 \dots\dots$
“ 19, “ low “ “		=	$681 \dots\dots$
Mean		=	647×10^{10}

This result is about four times as large as those found with thicker plates. Arguing from these facts alone, it would appear that the transverse effect in thin leaf gold is relatively much smaller than the effect in strips of sensible thickness, but this is hardly a safe conclusion. Three objections to the above method of determining the thickness by means of the resistance are evident; 1st, gold leaf so thin as to be transparent is by no means continuous, but is perforated by a multitude of small holes, so that the electricity is, as it were, obliged to wind or zigzag its way through the strip, thereby having a longer path and meeting a greater resistance, than if it could pursue a direct course: 2d, gold leaf is an alloy about twenty-three carats fine, and the resistance of such alloys is often much larger than that of either of the pure metals: 3d, it is difficult to secure good contact at the ends of the strip. In the plate under consideration this contact was probably very bad, and may have been many per cent of the whole resistance of the plate as measured.

All these sources of error affect the result in the same way. To compensate, it would be necessary to diminish the resistance as measured and then, in deducing the thickness, use a specific resistance higher than that belonging to gold. In using thin silver plates I have in a rough way made a correction for the error due to contact resistance, but the gold leaf is in several respects so unsuitable for anything like accurate work, that it does not seem worth while to spend any more time upon it at present. In fact I would in the present article dismiss the sub-

ject of gold *leaf* strips with a very few words, were it not the case that, in a matter of this kind, it seems proper that the public should be informed of any facts that have the slightest suspicious appearance.

The gold plates which are now to be described, were of comparatively thick metal, such as is used by dentists. The metal in this shape is said to be very pure, and the thickness was so considerable as to make it possible to weigh the strips with sufficient accuracy. The determination of the thickness in this way involves the assumption that the specific gravity is that given by the tables, but the error from this source must be very much smaller than the sum of those introduced by employing the resistance method.

Gold used by dentists is classed under various heads according to the manner of tempering. The kinds I have used are, I think, "soft," or possibly "semi-cohesive," and "hard," or "cohesive." I noted the varieties, thinking that specific peculiarities might possibly appear in their behavior. The number attached to each plate is the commercial number of the specimen and indicates approximately the number of grains in a sheet about ten cm. square. The letters attached are intended to distinguish different plates constructed from gold of the same number.

Gold Foil, No. 6 (A).

This strip was, I believe, of the kind called by dentists "hard," or "cohesive." To determine the thickness it was weighed before being attached to the glass. Previous experiment having shown the great variation in thickness between different parts of a sheet of gold foil, this strip was cut before weighing into nearly the same shape and size that it was to have on the glass.

The strip was in general shape a parallelogram with a projection from the middle of each of its longer sides. The use of these projections, which were much reduced in size before making the observations, has been already explained.

Length of strip when weighed	= 8.50 cm.
Width " "	= 2.14 " "
Area including projections	= 20.5 " sq.
Weight	= .0848 grms.

Taking the specific gravity of gold at 19.36, the value given by Ganot for "gold stamped," we find

$$\text{Thickness} = .000214 \text{ cm.}$$

With this plate many series of experiments were made, yielding most of the time results which were very discordant, owing to various disturbing causes, some known and others perhaps

unknown, to which allusion has already been made. The results obtained every day, except the last of my working with this plate, are so discordant, that in preparing them for publication it does not seem worth while to go over again the great mass of figures involved, for the purpose of correcting any small errors of calculation. The results obtained were

February 20th	$\frac{M \times V}{E'}$	=	134×10^{10}
“ “	“	=	136
“ 23d	“	=	163
“ “	“	=	159
“ “	“	=	166
“ 25th	“	=	160
“ “	“	=	149
“ “	“	=	157
“ 27th	“	=	152
“ “	“	=	147
Mean “	“	=	152×10^{10}

Replacing now the old perforated poles of the electro-magnet by solid new ones and removing one or two other sources of error, I found

March 5th	$\frac{M \times V}{E'}$	=	150×10^{10}
“ “	“	=	150
“ “	“	=	154
Mean “	“	=	1513×10^9

The strength of the magnetic field was, as usual, determined twice on March 5th, once before and once after the other observations. The two values varied by something more than one per cent. The mean of the two is taken as the uniform strength for the day. The strength of the primary current sent through the gold strip was much varied for the different series of observations.

Thus we may write as corresponding to the above three values

Strength of Field. M.	Strength of Primary Current. C.
6400	$k \times \tan 23^\circ 44'$
“	“ “ $42^\circ 14'$
“	“ “ $49^\circ 28'$

when k is the constant of the tangent galvanometer = .07 nearly.

The agreement between the mean of the various results previously obtained and the mean of those found March 5th, was considered satisfactory, and the next measurements were made with

Gold Foil, No. 5.

The metal in this plate was, I believe, either "soft," or "semi-cohesive."

Length of strip when weighed	=	8.49 cm.
Width " "	=	about 3.28 "
Area including projections	=	30.0 " sq.
Weight	=	.1122 grm.
Thickness	=	.000188 cm.

This strip after being placed on the glass was trimmed down to a width of about 2.32 cm., and the mean thickness of this strip was no doubt quite different from the value above obtained. This strip was reduced in width after being weighed more than any other that has been used, and this fact may account for the discrepancy between the results obtained with it and those obtained with the strips of No. 6, already described, and of No. 4, which is to be described next.

With No. 5 were made four series of observations, resulting thus :

	M.	C.	$\frac{M \times V}{E'}$
Mar. 8th,	6400	$k \times \tan 42^\circ 26'$	161×10^{10}
" "	6330	" " $26^\circ 2'$	163
" 10th,	6440	" " $22^\circ 48'$	162
" "	6440	" " $43^\circ 0'$	164
		Mean	$= \overline{1625} \times 10^9$

The next plate used was

Gold Foil, No. 4 (soft).

Length when weighed	=	7.64 cm.
Width " "	=	2.13 "
Area including projections	=	18.46 " sq.
Weight	=	.0478 grm.
Thickness	=	.000134 cm.

With this plate four series of observations were made in one day.

The results obtained March 12th were

	M.	C.	$\frac{M \times V}{E'}$
	6480	$k \times \tan 22^\circ 21'$	155×10^{10}
"	"	" " $26^\circ 25'$	155
"	"	" " $42^\circ 16'$	154
"	"	" " $28^\circ 43'$	154
		Mean	$= \overline{1545} \times 10^9$

Measurements had now been made with three plates of gold foil, and, considering the irregularity likely to be produced by the impossibility of determining accurately the effective thickness of the strips, the results seemed to agree satisfactorily,

indicating $\frac{M \times V}{E'}$ to be a constant for this metal. If the experiments in gold had begun with these particular plates, they would probably have ended with them for the present. Owing, however, to the great discrepancy observed between these results and those obtained with the very thin plates it seemed desirable to go further, and I therefore constructed a plate using

Gold Foil, No. 30 (A), (semi-cohesive?).

Length of strip when weighed	=	5.76 cm.
Width	"	1.085 "
Area including projections	=	7.36 " sq.
Weight	=	.161 grm.
. . . Thickness	=	.001129 cm.

With this plate

	M.	C.	$\frac{M \times V}{E'}$
Apr. 20th,	6520	$k \times \tan 48^\circ 38'$	123×10^{10}
" 23d,	6600	" " $31^\circ 30'$	124
" "	"	" " $40^\circ 39'$	128
		Mean	= 1250×10^9

This value is about twenty per cent lower than the mean of those obtained with the three plates, Nos. 4, 5, and 6, previously used. The discrepancy was so great, that another plate was made with a strip cut from the same sheet as No. 30 (A).

Gold Foil, No. 30 (B), (semi-cohesive?).

Length of strip when weighed	=	5.69 cm.
Width	"	1.08 "
Area including projections	=	7.33 " sq.
Weight	=	.149 grm.
. . . Thickness	=	.00105 cm.

It will be seen that the strips (A) and (B), cut from similar positions in the same sheet of metal, differ about seven per cent in mean thickness. The importance of this fact has already been pointed out. The difference in thickness thus found was so great, that I at first supposed a mistake must have been made in weighing the first strip, thereby giving too large a value for the weight. I therefore removed the strip from the glass plate and weighed it again. The result confirmed the original value obtained.

With the new plate, No. 30 (B), I found

	M.	C.	$\frac{M \times V}{E'}$
Apr. 26th,	6760	$k \times \tan 68^\circ 0'$	139×10^{10}
" "	"	" " $39^\circ 26'$	141
		Mean	= 1400×10^9

This value is much nearer those obtained with the plates 4, 5, and 6, but even now there is a discrepancy of eight or ten per cent. Without discussing this matter any further at present, I pass on to tell what has been observed with

SILVER.

Measurements have been made with four separate plates of this metal. The thickness of the strip was estimated in one case by weighing, in the three others by measuring the electrical resistance. I will give first the results obtained with the thick strip.

Silver Foil, No. 10.

Length of strip when weighed	=	7.98 cm.
Width " "	=	1.07 "
Area including projections	=	9.23 " sq.
Weight	=	.0474 gm.
. . . Thickness (taking sp. gr. to be 10.47)	=	.000491 cm.

With this plate

	M.	C.	$\frac{M \times V}{E'}$
Apr. 21st,	6580	$k \times \tan 49^\circ 17'$	114×10^{10}
" "	"	" " $32^\circ 20'$	118
		Mean	= 1160×10^9

Two of the other plates were prepared, not by fastening silver leaf to glass with shellac, but by depositing from a solution the silver directly upon the glass. The process made use of for this purpose was Böttger's, as detailed in this Journal for 1867. The two plates were cut from the same piece of glass after coating.

Silver Film (A).

Length between the contact blocks	=	6.05 cm.
Width	=	2.46 cm.
Electrical resistance, as measured,	=	1.45 ohms.

Knowing that the contact resistance must be quite a part of this value, I endeavored to determine its amount roughly in the following manner. Having obtained the above value, 1.45 ohms, and measured the distance between the blocks, I shortened the strip by placing the blocks nearer together, then measured the length and again determined the resistance of the whole. This process was repeated, thus giving three values of the resistance corresponding to the three lengths of the strip employed. From these values the contact resistance is readily determined, though of course very roughly. It appeared to be equal to the resistance of about 2.7 cm. of the strip itself, and

therefore in estimating the thickness of the strip from the electrical resistance, the effective length of the strip was taken to be not 6.05 cm., but 8.8 cm. Assuming the specific resistance of the silver in this plate to be .00000165 ohms, the value given by Jenkin for "hard drawn" silver, we obtain as the thickness of the strip .00000407 cm. It will be shown below that this value is probably very much too small, but I will for the moment give the results obtained on the basis of this estimation of the thickness.

Passing over a result obtained at quite an early period of the experiments, and which there are excellent reasons for rejecting, we have

	M.	C.	$\frac{M \times V}{E'}$
Jan. 30th,	7120	$k \times \tan 43^\circ 33'$	487×10^{10}
"	"	$" \quad " \quad 19^\circ 32'$	499×10^{10}
		Mean	493×10^{10}

The discrepancy between this result and that obtained with the thicker strip of silver was so great, that I determined to try

Silver Film (B).

I have assumed the thickness of (B) to be the same as that of (A). The other dimensions are about the same, and the result is

	M.	C.	$\frac{M \times V}{E'}$
May 4th,	6640	$k \times \tan 47^\circ 39'$	491×10^{10}

The agreement of this result with the mean of those just preceding is entirely satisfactory, and the discrepancy above mentioned, as existing between the results with plates of different kinds, is confirmed. This disagreement was so large as to be difficult to account for, without the hypothesis of a specific difference exhibited by different forms of the same metal, under the conditions of the experiment. To be sure the method of estimating the thickness from the electrical resistance was open to suspicion. Among other probable sources of error there was the possibility of having assumed a wrong value for the specific resistance of the silver in this condition. It did not appear to me probable that an error of about 400 per cent could be accounted for in this way, but it seemed worth while to attempt a determination of the thickness of the films by another method.

Plate (A) was taken and cleaned with alcohol to remove the particles of cement adhering to the glass and metal. The area of the silver film was roughly determined, and the plate was dried and, when cool, carefully weighed. The silver was

then removed by dissolving in nitric acid, after which the glass was again dried and weighed. In addition to this the solution of silver was filtered and treated with hydrochloric acid. The precipitate was filtered off, and the silver reduced by burning with the filter paper. The amount of silver on the glass was thus estimated in two ways. According to the weight lost by the plate the amount of silver appeared to be 4.3 mgr. while the amount obtained by the chemical process was only about 2.5 mgr. There are good reasons for thinking the former value too great and some reasons for thinking the latter too small. Giving the latter double weight in taking the mean we get $\frac{4.3+2 \times 2.5}{3} = 3.1$ mgr. for the amount of silver in the film.

The area covered by this on the glass was about 20 sq. cm. Taking the specific gravity of silver to be 10.5, we get for the thickness of the film

$$t = \frac{.0031}{20 \times 10.5} = .0000148 \text{ cm.}$$

This value is more than 3.6 times as large as that obtained by the resistance method. In order to make perfect accord between the results obtained with the two kinds of silver plates, the thickness would need to be rather more than four times as great as that obtained by the resistance method, but considering all the difficulties of the case, it seems to me that the large discrepancy still existing is within the limits of experimental error. In presenting the results of all the experiments in tabular form further on I shall give the results obtained with these silver films as calculated on the basis of the larger value, i. e., .0000148 cm., found for the thickness.

Mention is made above of a fourth plate of silver. This was also of a very thin film, but the silver was fastened to the glass with shellac instead of being deposited from a solution. The silver was in the same state as that of the thickest plate, and the results of measurements with it accord sufficiently well with those obtained with that plate. As the resistance method was employed in estimating the thickness, it does not seem worth while to publish the results obtained.

IRON.

Measurements have been made with three separate plates of iron. The first two plates were made early in the research and the quantitative results, like all others obtained at that time, are hardly reliable enough to be worth publishing.

The dimensions of the third strip were as follows :

Length as weighed	=	5.68 cm.
Width “	=	1.08 “
Area including projections	=	7.15 “ sq.
Weight	=	.193 grm.
∴ Thickness (taking sp. gr. = 7.79)	=	.00347 cm.*

With this plate the following results were obtained :

	M.	C.	$\frac{M \times V \dagger}{E'}$
Apr. 29th,	6680	$k \times \tan 38^\circ 37'$	-127×10^9
“	“	“ $49^\circ 13'$	$-130 \dots$
		Mean	$= -1285 \times 10^8$

PLATINUM.

One strip of this metal has been used.

Length as weighed	=	6.32 cm.
Width “	=	1.078 “
Area including projections	=	7.57 “ sq.
Weight	=	.457 grm.
∴ Thickness (taking sp. gr. = 22.1)	=	.00274 cm.

With this strip only one series of observations was made and that was rather a hasty one ; I found

	M.	C.	$\frac{M \times V}{E'}$
Apr. 28th,	6830	$k \times \tan 66^\circ 2'$	417×10^{10}

NICKEL.

There was some difficulty in obtaining a strip of this metal of proper shape for the experiment. The piece used was obtained by stripping off the nickel plating from a piece of brass, upon which the deposit had been purposely laid in such a manner as to make it easy to remove. The strip thus obtained was narrow and irregular in shape and its thickness cannot readily be determined at present, so that I do not attempt to give numerical results for this metal. The main object in using it was to determine the direction of the new effect therein, nickel being, next to iron and cobalt, the most strongly magnetic substance. As already stated, this direction was found to be oppo-

*The plates of very thin rolled iron used were furnished me by Prof. Rowland, who is indebted for a supply of the same to the courtesy of Prof. Langley of Allegheny Observatory.

† It is evident that the values of this ratio thus obtained for iron are to some extent, perhaps to a great extent, fictitious, for of course the strength of the magnetic field within the iron plate itself is the effective strength in the experiment, and this is probably very different from the value of M as determined by means of the test coil. It seems best, however, for the present, to employ this latter value of M, which must bear an intimate relation to the true value, and which has the great advantage of being easily determinable. Nickel has hardly been examined quantitatively as yet, and platinum is not sufficiently magnetic to present any difficulty of this sort.

site to that in iron. The action in nickel, though not really measured, was seen to be very decided, and may possibly prove to be as strong as that in iron.

TIN.

The action in this metal is very small and has not been measured with any accuracy. Its magnitude may be $\frac{1}{30}$ that of the action in gold.

No other conductors have been tested in such a manner as to warrant an expectation of detecting an action.

In the following table the results obtained with the different metals are brought together. Those obtained with very thin strips will be marked thus (?) for reasons which must be evident to any one who has read the preceding pages :

Metal Plate.	M.	C.	$\frac{M \times V}{E}$	
Gold. No. 6 ["hard"]			152×10^{10}	} 1515×10^9
" " "	6400	$k \times \tan 23^\circ 44'$	150×10^{10}	
" " "	6400	" " $42^\circ 14'$	150×10^{10}	
" No. 5 [soft or semi-cohes.]	6400	" " $49^\circ 28'$	154×10^{10}	} 1625×10^9
" " "	6400	" " $42^\circ 26'$	161×10^{10}	
" " "	6330	" " $26^\circ 2'$	163×10^{10}	
" " "	6440	" " $22^\circ 48'$	162×10^{10}	} 1545×10^9
" " "	6440	" " $43^\circ 0'$	164×10^{10}	
" No. 4 ["soft"]	6480	" " $22^\circ 21'$	155×10^{10}	
" " "	6480	" " $26^\circ 25'$	155×10^{10}	} 1250×10^9
" " "	6480	" " $42^\circ 16'$	154×10^{10}	
" " "	6480	" " $28^\circ 43'$	154×10^{10}	
" No. 30 (A) [semi-cohes. ?]	6520	" " $48^\circ 38'$	123×10^{10}	} 1400×10^9
" " "	6600	" " $31^\circ 30'$	124×10^{10}	
" " "	6600	" " $40^\circ 39'$	128×10^{10}	
" " (B) [semi-cohes. ?]	6760	" " $68^\circ 0'$	139×10^{10}	} 1160×10^9
" " "	6760	" " $39^\circ 26'$	141×10^{10}	
" " "	6580	" " $49^\circ 17'$	114×10^{10}	
Silver. No. 10	6580	" " $32^\circ 20'$	118×10^{10}	} $1355 \times 10^9 ?$
" [deposited] (A)	7120	" " $43^\circ 33'$	134×10^{10}	
" " "	7120	" " $19^\circ 32'$	137×10^{10}	
" " (B)	6640	" " $47^\circ 39'$		} $1350 \times 10^9 ?$
Iron (C)	6680	" " $38^\circ 37'$	-127×10^9	} 1285×10^8
" " "	6680	" " $46^\circ 13'$	-130	
Platinum	6830	" " $66^\circ 2'$		} 4170×10^9

Nickel—effect large, possibly as strong as in iron.
Tin—effect probably much smaller than in platinum.

This table enables us to arrange the metals so far examined, excepting nickel, in order with respect to the magnitude of the action observed in them. Opposite each metal in the following list is placed a number representative of this magnitude. In the case of gold this number is a quantity inversely proportional to the mean of the results obtained with the five different plates named above. In finding the corresponding number for silver, I have, for obvious reasons, used only the result obtained with the plate of No. 10. The representative number given for tin has been very roughly estimated and may be one

or two hundred per cent larger or smaller than the true number. All the numbers given must of course be taken as at best only rough approximations to the true representative numbers.

We find then

Iron	— 78·	Platinum	2·4
Silver	8·6	Tin	·2 (?)
Gold	6·8		

This arrangement is made on the basis of defining the magnitude of the action studied as a quantity inversely proportional to $\frac{M \times V}{E'}$. If on the other hand we were to define the same as inversely proportional to $\frac{M \times E}{E'}$, rather, E being the difference of potential of two points a centimeter apart on the longitudinal axis of the metal strip, the representative numbers would be relatively changed. The representative numbers on this new basis may be found by simply dividing each of the representative numbers given above by a quantity proportional to the specific electrical resistance of the metal to which the number is attached.

We thus obtain

Iron	— 80·	Platinum	2·6
Silver	57·	Tin	·15 (?)
Gold	32·		

It will be observed that the order of arrangement remains unchanged.

Platinum and tin are carried still farther from gold and silver than before, so that the range of the representative numbers is increased. It is plain, therefore, that by this second arrangement no progress has been made toward finding a constant representative quantity for all the metals. In dealing with the results obtained with different metals, it seems to be of little importance whether we take as our basis $\frac{M \times V}{E'}$ or $\frac{M \times E}{E'}$.

When, however, we have to do with different plates of the same metal, we see from the experiments on both gold and silver that the basis $\frac{M \times V}{E'}$ is by far the better one. We may sum up the matter by saying that according to present appearances:

1st, there is no constant representative quantity for all metals;

2nd, the basis $\frac{M \times E}{E'}$ does not give a constant representative quantity for different plates of the same metal;

3rd, the basis $\frac{M \times V}{E'}$ gives for different plates of the same metal a representative quantity which is approximately a constant.

It is evident, upon consideration, that this ratio $\frac{M \times V}{E'}$ could not be expected to give the same result for all metals. We get the quantity V by dividing the nominal cross section of our conductor by the strength of the current. We must, however, think of a metal as not strictly continuous, but consisting of metallic particles more or less compactly aggregated in the space occupied by the body as a whole. Evidently, therefore, the cross-section effective in conduction would vary in different conductors of the same nominal cross-section. It may, therefore, be found that different specimens, of the same metal but of different densities, will give quite different values for $\frac{M \times V}{E'}$.

Of course the magnitude of the new action in the different metals may be considered in connection with various other physical properties of the metal beside the specific electrical resistance. One might for instance expect to find some striking relation by comparing in this connection the known magnetic or diamagnetic properties of the metals. It is indeed to be observed that the most strongly magnetic substance, iron, does show the new action in a more marked degree than the other metals, and possibly nickel will come next in the list. Here the clue is entirely lost however, for the relative magnitude of the action in gold, silver, etc., is entirely out of proportion to the magnetic capacities of these metals.

On the whole we cannot be sure that any relation has yet been detected between the magnitude of the new action in the various metals and any known physical property of these metals. It is of course possible, however, that when more data shall have been obtained, analogies and relations at present unsuspected will appear. It can hardly be doubted that the action we have been considering, placing at our command, as it does, a new point of view from which to study the interior workings of the substances examined, is destined to teach us a good deal in regard to the molecular structure of bodies, while helping us toward an understanding of the physical nature of electricity and magnetism.

We return now to the remarkable anomaly presented by the direction of the action in iron. That the direction in this metal, a magnetic substance, should be different from that in gold, a diamagnetic substance, is remarkable, but not perhaps surprising. We find, however, that nickel and platinum, both magnetic substances, resemble in the particular above mentioned, not iron, but gold, and the other diamagnetic substances. This fact has to be taken into account in endeavoring to apply the newly discovered action to explain the magnetic rotation of the plane of polarization in accordance with

the principles of Maxwell's electro-magnetic theory of light. Professor Rowland, therefore, in view of this difference of behavior of iron and nickel with respect to electricity, was very desirous to know whether these two metals would manifest a similar disagreement in their action upon light. I have, therefore, at his suggestion, repeated Kerr's experiment on the rotation of the plane of polarization of light by reflection from the pole of a magnet, using nickel for the latter instead of iron. The reflecting surface used was the nickel plating on one of the disks of Professor Rowland's absolute electrometer. This disk for the purpose of the experiment was placed between the poles of the electro-magnet. The action upon the plane of polarization, though apparently much weaker than in iron, has, in the plate used, unmistakably the same direction. This nickel plating, however, was executed in Germany, and Professor Rowland thinks that, as the nickel of that country is very impure, this specimen may possibly contain iron enough to mask the true action of the nickel.

I have already spoken of the fact that, when a strongly magnetic substance is experimented upon, complications are introduced by the influence of the induced magnetism which affects the condition of the magnetic field through which the current flows, making the value of M different from that determined by means of the test coil. It does not seem probable that in this fact can be found an explanation of the anomalous behavior of iron, but there is no doubt that an interesting research is here suggested. For instance, it might be profitable to subject to experiment a thin plate of hard steel and determine to what extent the permanent magnetization induced therein by the electro-magnet would be accompanied by a permanent change in the equipotential lines after the electro-magnet had ceased to act.

It is perhaps idle to speculate as to the exact manner in which the action between the magnet and the current takes place in any of the preceding experiments, but it may be worth while to remark a seeming analogy, somewhat strained perhaps, between this action and a familiar mechanical phenomenon, the theory of which has of late attracted considerable attention. It is well known that a base ball projected swiftly through the air and having at the same time a rapid motion of rotation about its vertical axis does not throughout its course continue in its original vertical plane of its motion, but follows a path curving sensibly to one side. Imagine now an electrical current to consist of particles analogous to the base ball, moving through a metallic conductor the electrical resistance of which will correspond to the mechanical resistance offered by the air. Suppose, further, the particles of elec-

tricity, on coming within the influence of the magnet, to acquire a motion of rotation about an axis parallel to the axis of the magnet.* Under all these supposed conditions we might perhaps expect to find the action which is actually detected. To account for the reversal of the action in iron, we might suppose the particles of electricity to acquire in this metal a rotation about the same axis as in the other metals, but in the opposite direction. Even after all these generous concessions in favor of our hypothesis, however, it fails to account for the behavior of nickel, as different from that of iron. The analogy, such as it is, which has been pointed out, is perhaps curious rather than significant.

Historical.

I am not aware that investigators, during the first part of the century, made any attempt to discover the phenomenon which has been the subject of the observations described in the preceding article. Wiedemann,† however, mentions two investigators who have at different times given the subject their attention. The first of these in point of time was Feilitzsch.‡ He made use of two flat spirals of wire, through each of which an electric current was made to pass. These currents, passing in opposite directions through the coils of a differential galvanometer, were so adjusted that their combined action produced no effect upon the needle. A third spiral, similar to the others and itself bearing a current, was now brought near one of these and the galvanometer was observed. No permanent deflection of the needle was detected, and therefore no permanent action of one current on the other was discovered. I have not had access to the original article and cannot say what the author's theory of the experiment may have been. The method of attacking the problem seems however to have been similar in principle, to that which I at first adopted, viz: an endeavor to increase the resistance experienced by an electrical current by diverting it from its normal course through the conductor.

Another research in this direction mentioned by Wiedemann was that of Mach.§ This investigator covered a circular disk of silver leaf with wax and applied the poles of a battery to points diametrically opposite each other on the circumference of the disk. The silver leaf becoming heated by the cur-

* Maxwell (*Electricity and Magnetism*, vol. ii, p. 416) says, "I think we have good evidence for the opinion that some phenomenon of rotation is going on in the magnetic field, that this rotation is performed by a great number of very small portions of matter, each rotating on its own axis, this axis being parallel to the direction of the magnetic force," etc.

† *Galvanismus*, vol. ii, p. 174.

‡ *Berichte der Naturforscher in Karlsruhe*, 1858, p. 151, etc.

§ *Carl's Repertorium*, vol. vi, p. 10, 1870.

rent, the wax began to melt and melted most rapidly where the current was strongest, thus roughly showing the distribution of the stream. The plate still bearing the current was now subjected to the action of an electro-magnet, but no change could be detected in the behavior of the melting wax, the current remaining apparently unchanged in its course through the disk. This experiment therefore, like the preceding, was negative in its indications.

A recent number of the "Beiblätter zu Wiedemann's *Annalen*" mentions, in connection with the researches of Feilitzsch and Mach, another by Gore.* The latter took a wire bifurcated throughout a part of its length and passed through it a current sufficiently strong to raise both branches to a white heat. He then endeavored by means of a magnet to divert the current somewhat from one branch of the wire and draw into the other branch more than its normal share. It was thought that an unequal division of the current might show itself by a change in the appearance of the white hot branches. No change of this kind could be detected, and the investigator therefore concluded that the action known to take place between conductors bearing currents, was not an action between the electric currents as such. Gore expressly states that he undertook this experiment not knowing that any previous investigations with the same aim had ever been made.

On the same page of the "Galvanismus" which treats of the research of Mach, as mentioned above, Wiedemann describes, as a means of showing that no action takes place between permanent electric currents as such, almost the exact arrangement of apparatus with which the discovery was finally made. Who first used this apparatus for this purpose I cannot say, unless it may have been Wiedemann himself. The same plan was hit upon by Professor Rowland,† quite independently I believe, and he experimented to some extent in this direction about the year 1876. The same arrangement was finally adopted by me after another method of attacking the problem had been unsuccessfully tried.

I desire to express my sense of obligation to the professors and students of the physical department of the Johns Hopkins University, for the generous assistance which they have rendered me during the progress of this research.

* "On the Attraction of Magnets and Electric Currents."—*Phil. Mag.* (4th series), vol. 48, p. 393, 1874.

† *Amer. Jour. of Math.*, vol. ii, p. 289.